

ÇALIŞMA SICAKLIKLARI/WORKING TEMPERATURE (°C)

	EN DÜŞÜK DAYANIM SICAKLIĞI MINIMUM TEMPERATURE	EN YÜKSEK DAYANIM SICAKLIĞI MAXIMUM TEMPERATURE	
		KURU ORTAM SICAKLIĞI DRY ENVIRONMENT	ISLAK ORTAM SICAKLIĞI WET ENVIRONMENT
Asetal LF/Acetal LF	-40	+85	+70
Asetal D/Acetal D	-40	+85	+70
Güçlendirilmiş Polipropilen/Reinforced Polypropylene	+5	+105	+105
Polyamid/Polyamide (PA6)	-5	+80	+90
Güçlendirilmiş Polyamid/Reinforced Polyamide (PA6)	-10	+120	+120
Polietilen 1000/UHMW-PE ALPOLEN® 1000	-40	+80	+70
430 Kalite Paslanmaz Çelik/AISI 430 SSC	-40	+260	+120
304 Kalite Paslanmaz Çelik/AISI 304 SSS	-40	+400	+120
Karbonca Zenginleştirilmiş Çelik/Treated Steel (S)	-40	+180	+120

DAYANIM YÜKÜ/MAX. BREAKING LOADS

	M	Newtons
815	SSS	10200
	SSC	10400
805	SSS	1900
	SSC	1900
810	SSS	4500
	SSC	4500
815	SSS	10400
820	LF	3200
821	LF	6500
880	LF	5200
881	SSS	10000
	SSC	9500
882	LF	8000
900	D	4000
450	AW	1500
400	AW	6500
550	LF	6500
600	AW	8000
610	AW	8000
1700	AW	6500



Yapılan ARGE'ler sonucunda;

*Antistatik Malzemeler

*Yüksek Sıcaklıklar

*Ultraviyole Dirençli Işınlar gibi koşullar,kullanılan hammaddede sonuçlarını etkileyerek teknik verilerde sapmalara yol açabilir.

Our constantly developing engineering department,in collaboration with the leading raw materials suppliers,offers our clients the possibility of specific solutions to suit their particular application needs.

*Antistatic Material.

*High Temperatures.

*Ultraviolet Ray Resistant.

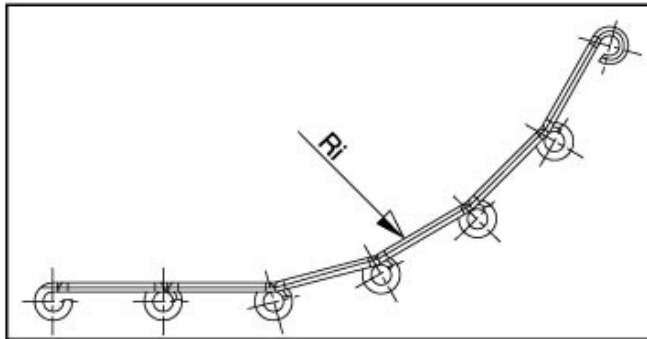
KULLANILABİLİR DÖNÜŞ ARALIKLARI/BACK BEND RADIUS

	Ri
400	300
450	150
515	75
550	50
805	150
810	75
815	150
843	90
863	125
900	0
881	50
882	50
1873	250
1873G	100